

Waste Pre-Shredders from Metso Waste Recycling
M&J PreShred 1000S

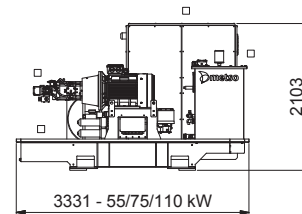

M&J PreShred 1000S

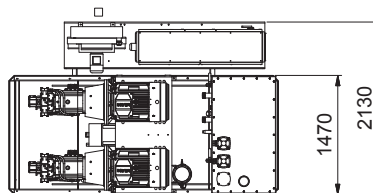
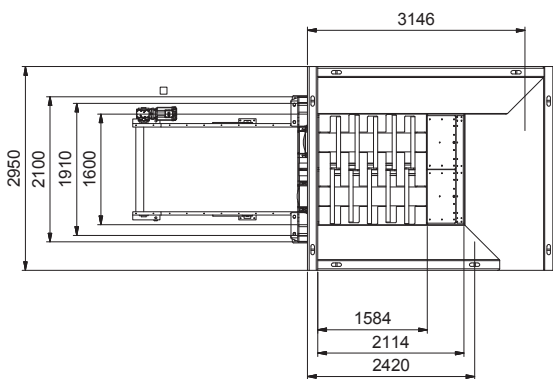
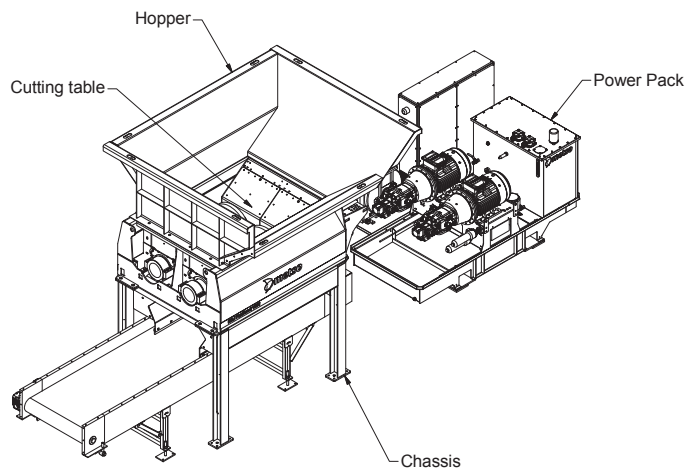
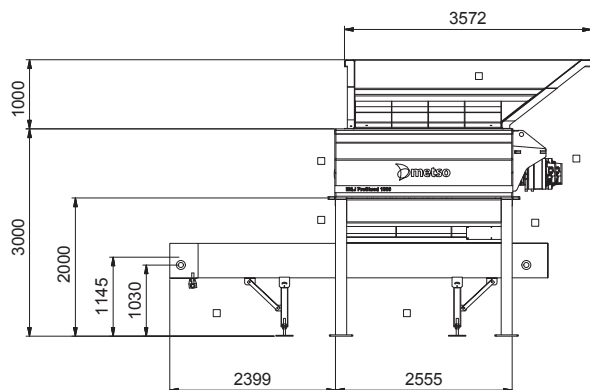

Specification		
Overall dimension std without hopper (LxWxH)	mm	5391 x 2100 x 3000
Weight (total included standard conveyer)	ton	13.2 – 16.0
Standard colour	RAL	7011, 9002
Loading height (without hopper)	mm	3000
Cutting area	mm	1584 x 1600
Power pack		
Electric motor	kW	2x55 / 2x75 / 2x110
Electric control unit		PLC
Drive principle		Double hydrostatic transmission
Chassis		
Standard belt conveyer (LxW)	mm	5000 x 1200
Discharge height	mm	1030
Discharge width	mm	1200
Weight (included / exclusive conveyer)	ton	2.1 / 1.1

Cutting table



Cutting table 5 knives

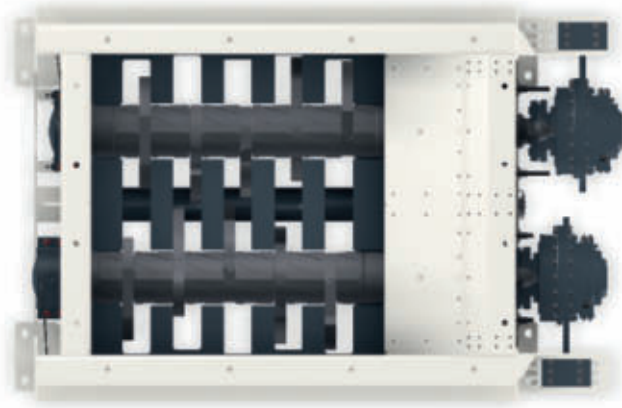

Cutting table 7 knives

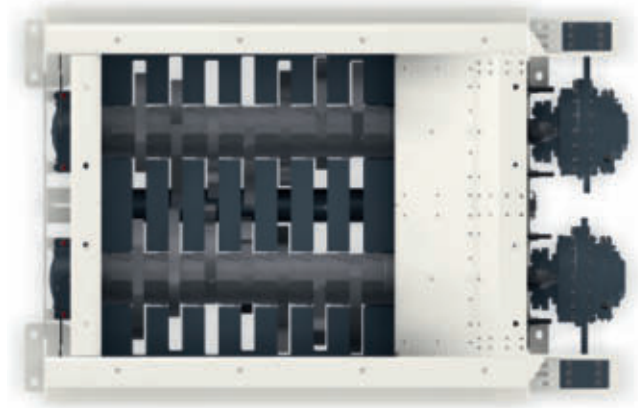

M&J PreShred 1000S

Cutting Table		
Number of shafts		2
Rotating speed*	rpm	14-55 / 10-35 / 12-49
Number of knives		5 / 6 / 7
Number of counter knives		10 / 12 / 14
Cutting area (LxW)	mm	1584 x 1600
Weight	ton	7.9 – 8.7
Grain size		
5 knives	mm	<350
6 knives	mm	<250
7 knives	mm	<150
Capacity per hour **		
Household waste	ton	Up to 40
Demolition wood	ton	Up to 30
Industrial waste	ton	Up to 15
Bulky waste	ton	Up to 20
* Standard / Reduced speed, high torque / HDC ** 90% less than		
*** Depending on loading, grain size and density of the input material		



For more information, contact your local Metso Waste Recycling representative, or contact your dealer directly.

Metso Denmark A/S
Vejlevej 5
DK-8700 Horsens
Denmark
Tel: +45 7626 6400
Fax: +45 7626 6449
recycling.info.dk@metso.com

www.metso.com/recycling

We reserve the right to make changes and improvements without notice, "M&J PreShred 1000S". Metso Waste Recycling, March 2017