

M&J PreShred 4000S with butterfly knives  
The perfect bag opener







## We do the job right

Metso Waste Recycling has developed a special cutting table for our well-known M&J 4000 series.

A shredder that doesn't do too much damage but, nevertheless, does exactly what is required of it – in other words, it's the perfect bag opener for light packing material.

The new bag opener has been designed to ensure that all bags are opened and that all recyclable materials retain their shape so that they can be sorted at a later stage. Due to the new collecting system, future material will inevitably have a more diverse composition, therefore, the feedstock must be more homogenized than before to prevent plant downtime caused by the material.

## Cutting table technology

The cutting table is equipped with two rotating shafts, each with 2x7 special knives and transverse counter knives with no middle bar. The transverse knives can be replaced as they have been mounted with bolts.

## Trust in our experience

The first machine in this configuration was put into operation in 2013 and today, four and a half years later, it has run 12,000 hours with an average capacity of 30 ton/hour. In 2015, an old M&J PreShred 4000 stationary was refurbished to meet the demand for bag-opening. At that time, it had already been in operation for 26,000 hours. Now, in October 2017, it has reached over 40,000 hours, also with a capacity of 30 ton/hour. Further installations have been – and are – realized continuously.

Calculated from knowledge and experience gained through thousands of operational hours, we can guarantee an opening rate of around 99%. Hard plastics and similar materials are shredded in such a way that they can later be sorted more efficiently. The capacity achieved with this machine is approximately 30 ton/hour.

## Seeing is believing

To provide you with all the information and insight into the high-quality bag-opening cutting table and what it can do for your operation, we find that the best way is to arrange an on-site demonstration and test using our mobile unit operated by our skilled team. The aim is to provide you with a clear idea of the performance and efficiency of our PreShredders, and to offer you a unique opportunity to validate these performance figures using your own material.



# M&J PreShred 4000S

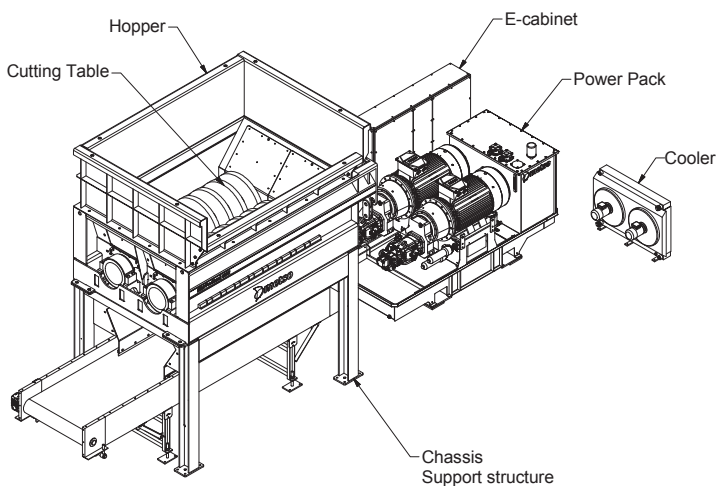
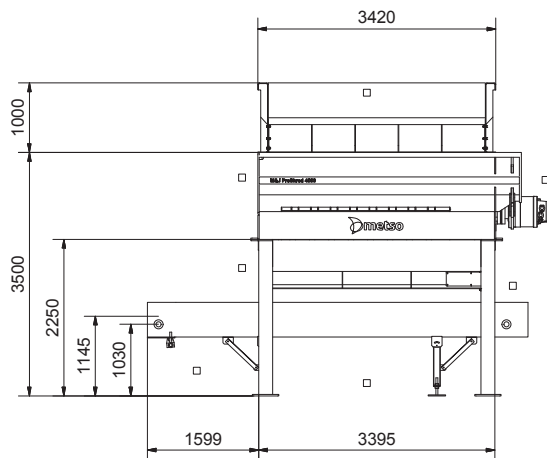

Butterfly

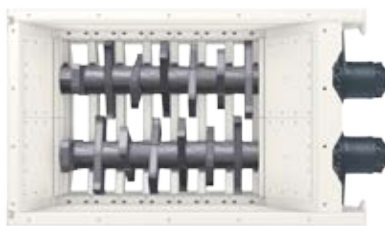

Cutting table 7 knives



Specification			
Overall dimensions std without hopper (LxWxH)	mm		5536 x 2300 x 3500
Weight (total including standard conveyer)	ton		20.5 – 23.5
Standard colour	RAL		7011, 9002
Loading height (without hopper)	mm		3500
Cutting area	mm		2420 x 2000
Power pack			
Electric motor	kW		2x75 / 2x110 / 2x132 / 2x160 / 2x200
Electric control unit			PLC
Drive principle			Double hydrostatic transmission
Chassis			
Standard belt conveyer (LxW)	mm		4500 x 1200
Discharge height	mm		1145
Discharge width	mm		1200
Weight (with / without conveyer)	ton		2.8 / 1.8
Cutting Table			
Number of shafts			2
Rotating speed (standard)	rpm		16-40 / 26-55
Number of knives / counter knives			7 / 14
Weight	ton		12.5 – 14.9

# To meet our customers' needs

## The Metso Way

**MAKING THE BIG DIFFERENCE**

The message that covers everything we do



### **knowledge**

We have deep knowledge about our customers' business environment, processes and challenges



### **people**

Our committed and highly competent people make the difference to our customers



### **solutions**

We create the technology and services required to meet our customer needs



Metso Waste Recycling  
Vejløvej 5  
DK-8700 Horsens  
Tele: +45 7626 6400  
recycling.info.dk@metso.com

[www.metso.com](http://www.metso.com)

We reserve the right to make changes and improvements without notice, "M&J PreShred LVP". November 2017 (151888)